

# Model 7114A Accelerometer



IEPE Accelerometer  
High Sensitivity, 1000mV/g  
10-32 Side Connector  
Stud Mount, Hermetic

**The Model 7114A** is a high performance IEPE accelerometer available in  $\pm 5g$  to  $\pm 50g$  dynamic ranges. The stud mounted accelerometer features a welded hermetic construction with a side mount connector. The model 7114A incorporates stable piezo-ceramic crystals in annular shear mode which provide a wide bandwidth. The standard operating temperature range extends from  $-55^{\circ}\text{C}$  to  $+125^{\circ}\text{C}$ . For a miniature stud mount version please review model 7104A, available in  $\pm 50g$  to  $\pm 500g$  dynamic ranges

## FEATURES

- $\pm 5g$  to  $\pm 50g$  Dynamic Range
- High Sensitivity, 1000mV/g
- Welded Construction
- Hermetically Sealed
- Annular Shear Mode
- Stable Temperature Response

## APPLICATIONS

- Vibration & Shock Monitoring
- Laboratory Testing
- Modal Applications
- High Frequency Applications
- General Purpose Usage



## dimensions

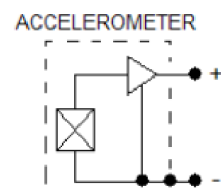
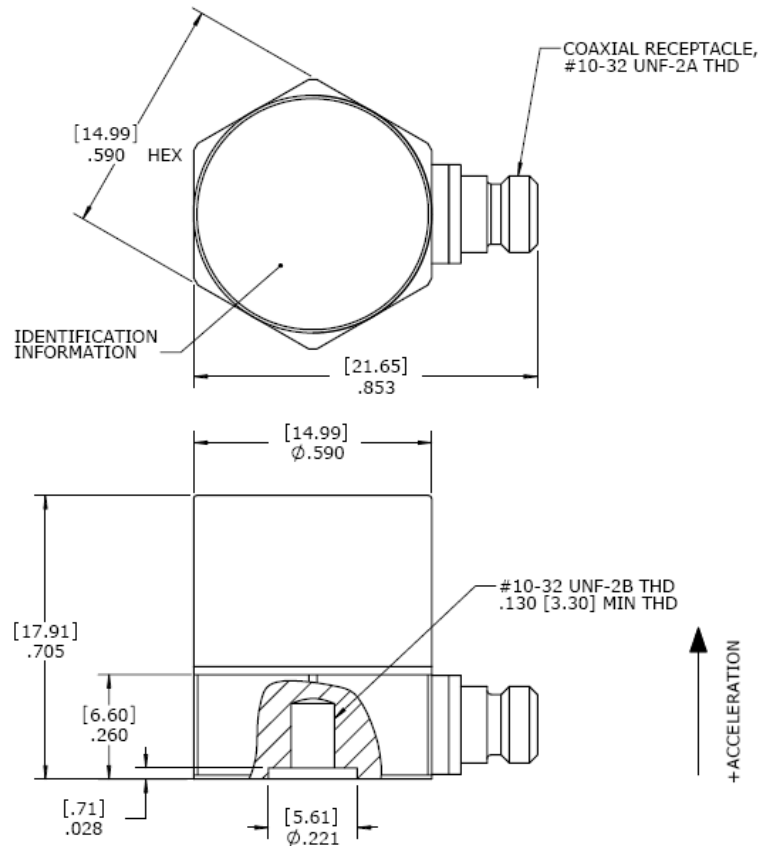

# Model 7114A Accelerometer

## performance specifications

All values are typical at +24°C, 80Hz and 4mA excitation unless otherwise stated. Measurement Specialties reserves the right to update and change these specifications without notice.

Parameters				Notes
<b>DYNAMIC</b>				
Range (g)	±5	±10	±50	
Sensitivity (mV/g)	1000	500	100	
Frequency Response (Hz)	1-4000	1-5000	1-8000	±5%
Frequency Response (Hz)	0.5-5000	0.5-6000	0.5-9000	±1dB
Natural Frequency (Hz)	26000	28000	30000	
Phase Response (Hz)	1-2000	1-2000	1-2500	<5°
Non-Linearity (%FSO)	±1	±1	±1	
Transverse Sensitivity (%)	<5	<5	<5	
Shock Limit (g)	5000	5000	5000	
Residual Noise (g RMS)	0.0001	0.0002	0.0004	Broadband 1Hz to 10kHz
<b>ELECTRICAL</b>				
Compliance Voltage (Vdc)	18 to 30			
Excitation Current (mA) <sup>1</sup>	2 to 10			See Note 1
Bias Voltage (Vdc)	8 to 12			Room Temperature
Bias Voltage (Vdc)	6 to 13			-55 to +125°C
Output Impedance (Ω)	<100			
Full Scale Output Voltage (V)	±5			
Discharge Time Constant (sec)	0.8 to 1.2			
Grounding	Case Grounded			
<b>ENVIRONMENTAL</b>				
Temperature Response (%)	±5			
Operating Temperature (°C)	-55 to +125			
Storage Temperature (°C)	-55 to +125			
Humidity	Hermetically Sealed, IP67			
<b>PHYSICAL</b>				
Sensing Element	Ceramic (shear mode)			
Case Material	Stainless Steel			
Weight (grams)	19			
Mounting	#10-32 to #10-32 Mounting Stud (included)			
Mounting Torque	18 lb-in (2.0 N-m)			

<sup>1</sup> Maximum 4mA at +125°C

<b>Calibration supplied:</b>	CS-FREQ-0100	NIST Traceable Amplitude Calibration from 20Hz to ±1dB Frequency Response Limit
<b>Supplied accessories:</b>	AC-D02298	10-32 to 10-32 mounting stud
<b>Optional accessories:</b>	310-XXX	Cable Assembly, 10-32 to 10-32 (XXX designates length in inches, 10ft standard)
	314-XXX	Cable Assembly, 10-32 to BNC (XXX designates length in inches, 10ft standard)
	AC-A03470	Adhesive Mounting Adaptor
	AC-A03471	Magnetic Mounting Adaptor
	161A	4-Channel PE & IEPE Signal Conditioner

The information in this sheet has been carefully reviewed and is believed to be accurate; however, no responsibility is assumed for inaccuracies. Furthermore, this information does not convey to the purchaser of such devices any license under the patent rights to the manufacturer. Measurement Specialties, Inc. reserves the right to make changes without further notice to any product herein. Measurement Specialties, Inc. makes no warranty, representation or guarantee regarding the suitability of its product for any particular purpose, nor does Measurement Specialties, Inc. assume any liability arising out of the application or use of any product or circuit and specifically disclaims any and all liability, including without limitation consequential or incidental damages. Typical parameters can and do vary in different applications. All operating parameters must be validated for each customer application by customer's technical experts. Measurement Specialties, Inc. does not convey any license under its patent rights nor the rights of others.

## ordering info

PART NUMBERING Model Number+Range

7114A-GGGG  
|\_\_\_\_ Range (0050 is 50g)

Example: 7114A-0050  
Model 7114A, 50g